

MODEL : BV-202 [Two Piece Body Ball Valve Full Port]

Connection : ANSI 150, 300



◆ SPECIFICATION

Valve Design : ASTM / ANSI B16.34
 Steel Casting : MSS SP-55
 Face to face : ASTM / ANSI B16.10
 Flange connection : ANSI CLASS 150-300
 Pressure test : API 598 (ISO 5208)
 Sulfide stress cranking : NACE MR-01-75

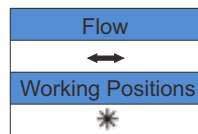

- ◆ Suitable for :
1. Water
 2. Oil
 3. Gases

◆ FEATURES

1. Anti Static device
2. Fire safe design

◆ MATERIAL LIST

No.	Part Name	Material		
1	Body	ASTM A216-WCB	SS304	SS316
2	Bonnet	ASTM A216-WCB	SS304	SS316
3	Nut	CS	SS304	SS316
4	Bolt	CS	SS304	SS316
5	Ball	SS304	SS304	SS316
6	*Seat	PTFE	PTFE	PTFE
7	Gasket	PTFE	PTFE	PTFE
8	Stem	SS304	SS304	SS316
9	Stem Packing	PTFE	PTFE	PTFE
10	Gland Flange	ASTM A216-WCB	SS304	SS316
11	Gland Bolt	ASTM A216-WCB	SS304	SS316
12	Stop Collar	ASTM A216-WCB	SS304	SS316
13	Lever	ASTM A216-WCB	FC400	FC400
14	Circlip	ASTM A216-WCB	WCB	SS316

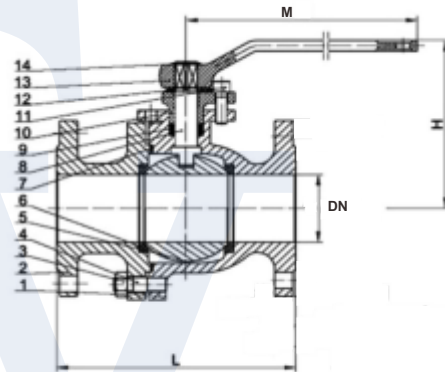

*OPTION :

1. PEEK
2. 15% Glass PTFE
3. 25% Carbon Full PTF
4. TFM 1600

◆ DIMENSIONS (mm)

Class 150															
Size	Inch	1/2	3/4	1	1-1/2	2	2-1/2	3	4	5	6	8	10	12	
L-RF	mm	103	117	127	165	178	191	203	229	356	394	457	533	610	
DN (B)	mm	13	19	25	38	51	64	76	102	125	152	203	254	305	
H	mm	60	64	75	98	108	143	155	178	252	275	340	345	479	
M	mm	130	130	165	205	205	300	340	400	700	850	1100	1200	1500	
Torque (Nm)	Nm	5.5	7.2	8.8	20	24	54	62	124	230	260	360	605	880	GREASE
	Nm	7.2	9.4	13	18.2	30	36	95	132	245	-	-	-	-	NON-GREASE
Weight	mm	2.3	3	4.5	7	9.5	15	19	33	53	93	160	200	364	

Class 300															
Size	Inch	1/2	3/4	1	1-1/2	2	2-1/2	3	4	5	6	8	10	12	
L-RF	mm	140	152	165	190	216	241	283	305	381	403	502	568	-	
DN (B)	mm	13	19	25	38	51	64	76	102	125	152	203	254	-	
H	mm	60	64	75	98	108	143	155	178	252	275	340	345	-	
M	mm	130	130	165	205	205	300	340	400	700	850	1100	1200	1500	
Torque (Nm)	Nm	8.2	9.8	13	26.9	33.7	71.3	84.6	157	-	-	-	-	-	GREASE
	Nm	11.5	13.7	19	43.7	60.7	142.6	178	329	-	-	-	-	-	NON-GREASE
Weight	mm	2.5	3.5	5.5	10	15	26	35	56	93	116	233	423	-	

Specification is subject to change without prior notice